

Whether you're sampling soils in an environmental investigation, collecting geotechnical data for construction, penetrating rock for bedrock wells, or casing a hole for a geothermal project, you'll find the sonic tooling system required to successfully achieve the desired results. Our sonic soil sampling tooling offers you the widest array of bits and sampling systems available; from conventional telescoping soil coring to dual tubing and face flushing bits for rock coring.

With sonic rigs and tooling designed and manufactured as a holistic system, you'll benefit from a comprehensive, compatible offering that is:

- Engineered and tested for maximum strength and durability during sonic drilling by folks who manufacture sonic drill rigs
- Manufactured with solid steel using an exclusive heat treatment process and a proprietary thread design for ease of make-up and break-out.
- Supported by sonic drilling experts experienced with tooling in a variety of geologic settings who can advise you in tooling selection and sonic drilling application technique.

Geoprobe® sonic casing is available on the shelf in a variety of lengths, providing you many options and configurations for reliable and consistent sonic project results, such as:

- Conventional Sonic Sampling (4x6, 6x8, 8x10)
- Dual Tube Sonic Sampling (SDT45 & SDT60)
- Single Casing System: Cased Hole w/o Sampling



**INDUSTRY
FIRST**

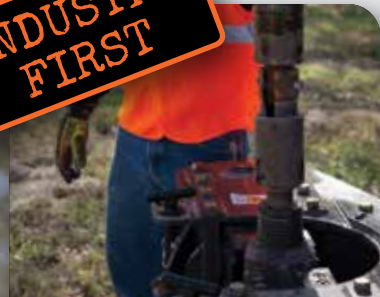

2
0
1
5

Geoprobe® Sonic
Weighted
Wireline



*Collecting a soil sample
with the Geoprobe® Sonic
Weighted Wireline System*

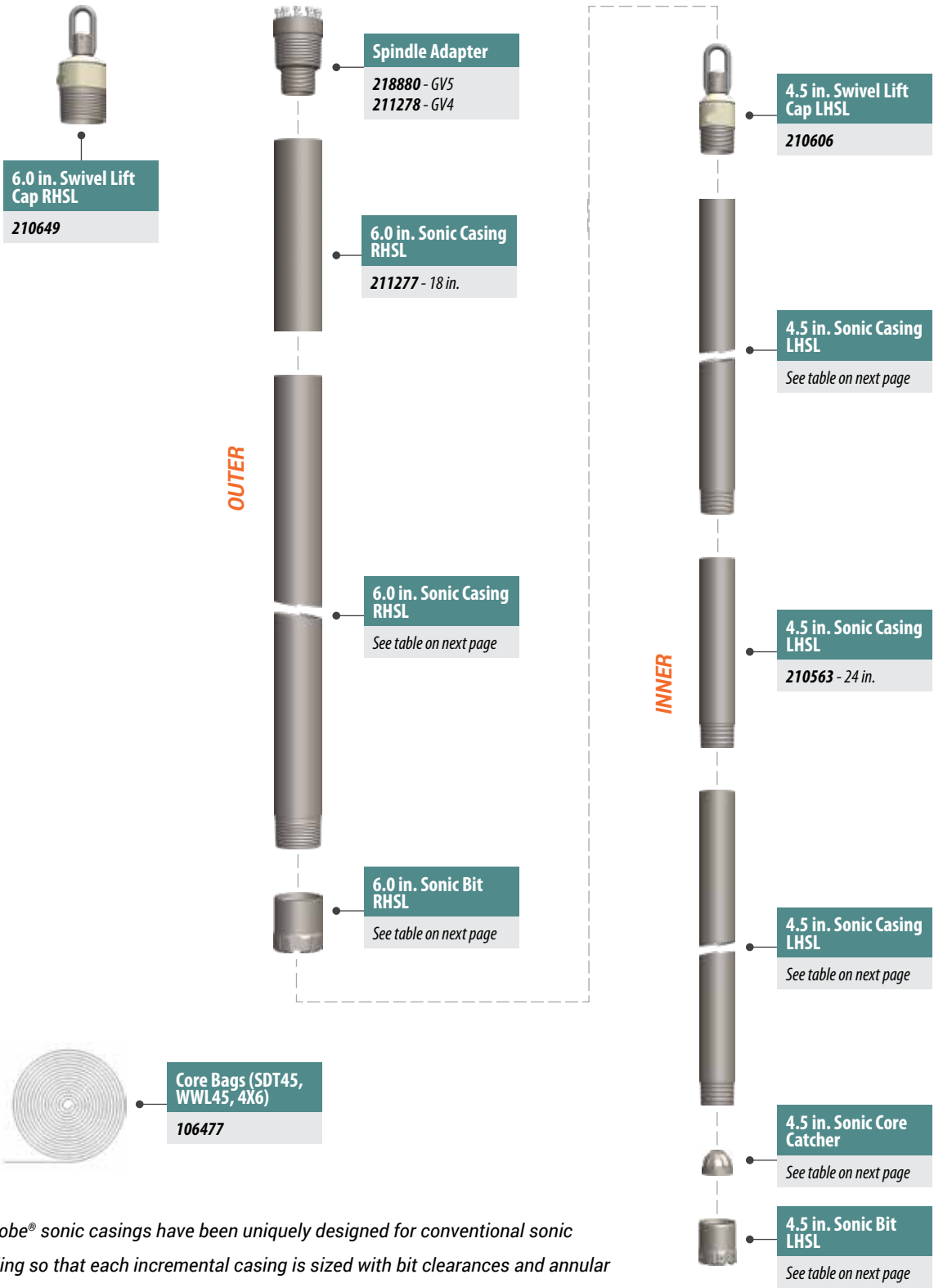





Geoprobe® sonic casings have been uniquely designed for conventional sonic sampling so that each incremental casing is sized with bit clearances and annular space in mind. The 4x6 method is a well-established configuration that uses a 4-in. nominal core barrel over cased with a 6-in. casing.

OUTER

6.0 in. Sonic Casing RHSL



| Components | MN | Length | Weight | OD | ID |
|---|--------|---------|------------|---------|----------|
|  | 210979 | 120 in. | 225 lbs. | 6.0 in. | 5.25 in. |
| | 210648 | 60 in. | 112.5 lbs. | | |
| | 211174 | 24 in. | 45 lbs. | | |
| | 211277 | 18 in. | 33.75 lbs. | | |
| | 212350 | 12 in. | 22.5 lbs. | | |
| | 212351 | 6 in. | 11.25 lbs. | | |

Bits

| Components | Part | MN | Notes |
|---|---|--------|----------------------------|
|  | 6.0 in. Sonic Bit RHSL, Dome | 210749 | 6.38 in. OD 5.02 in. ID |
|  | 6.0 in. Sonic Bit RHSL, Para | 213325 | 6.45 in. OD 5.02 in. ID |
|  | 6.0 in. Sonic Bit RHSL, Dome Hardfaced NEW | 237966 | 6.38 in. OD 5.02 in. ID |
|  | 6.0 in. Sonic Bit RHSL, Para Hardfaced NEW | 237967 | 6.45 in. OD 5.02 in. ID |

COMBINED COMPONENTS







Spindle Adapters

| Components | Part | MN | Notes |
|---|---|--------|-------|
|  | GV5 ADPT 6.0 RHSL x 4.5 LHSL x 3.5 LHSL | 218880 | |
|  | GV4 ADPT 6.0 RHSL x 4.5 LHSL x 3.5 LHSL | 211278 | |

Subs / Adapters

| Components | Part | MN | Notes |
|---|-----------------------------|--------|---------------------------|
|  | 4.5 LHSL Box x 4.5 LHSL Pin | 212679 | 4.00 in. S-S Sub Saver |

Accessories



| Components | Part | MN | Notes |
|---|----------------------------------|--------|----------------------|
|  | 6.0 in. Threadless Pin Sand Slip | 216182 | |
|  | 6.0 in. Swivel Lift Cap RHSL | 210649 | Pin |
|  | 4.5 in. Swivel Lift Cap LHSL | 210606 | Pin |
|  | Rod Wiper Donut | 600624 | 6.0 in. |
|  | Rod Wiper Donut | 600448 | 4.5 in. |
|  | Core Bags (SDT45, WWL45, 4X6) | 106477 | 8 in. flat x 725 ft. |
|  | Thread Compound | 600729 | 1 Gallon |

INNER













4.5 in. Sonic Casing LHSL

| Components | MN | Length | Weight | OD | ID |
|---|--------|---------|-----------|---------|----------|
|  | 210172 | 120 in. | 165 lbs. | 4.5 in. | 3.75 in. |
| | 210495 | 60 in. | 82.5 lbs. | | |
| | 210563 | 24 in. | 33 lbs. | | |
| | 210602 | 12 in. | 16.5 lbs. | | |

Core Catchers

| Components | Part | MN | Notes |
|---|----------------------------|--------|-----------|
|  | 4.5 in. Sonic Core Catcher | 209675 | LH |
|  | 4.5 in. Sonic Core Catcher | 231171 | LH, Short |
|  | 4.5 in. Sonic Core Catcher | 213151 | LH, Thin |

Bits

| Components | Part | MN | Notes |
|---|--|--------|----------------------------|
|  | 4.5 in. Sonic Bit LHSL, Dome | 210569 | 4.88 in. OD 3.53 in. ID |
|  | 4.5 in. Sonic Bit LHSL, Para | 215168 | 4.95 in. OD 3.52 in. ID |
|  | 4.5 in. Sonic Bit LHSL, Dome Hardfaced NEW | 237956 | 4.88 in. OD 3.53 in. ID |
|  | 4.5 in. Sonic Bit LHSL, Para Hardfaced NEW | 237957 | 4.95 in. OD 3.52 in. ID |
|  | 4.5 in. Sonic Bit LHSL Undercut, Para | 212514 | 4.90 in. OD 3.32 in. ID |
|  | 4.5 in. Sonic Bit LHSL Undercut, Para Hardfaced NEW | 237961 | 4.90 in. OD 3.32 in. ID |
|  | 4.5 in. Sonic Bit LHSL Undercut ID Carbide, Para | 213481 | 4.90 in. OD 3.15 in. ID |
|  | 4.5 in. Sonic Bit LHSL, Para | 221895 | 4.75 in. OD 3.75 in. ID |
|  | 4.5 in. Sonic Bit LHSL CC | 226269 | 4.50 in. OD 3.75 in. ID |
|  | 4.5 in. Sonic Bit LHSL Flapper Single | 226328 | 4.75 in. OD 3.75 in. ID |
|  | 4.5 in. Sonic Bit LHSL Flapper Double | 224628 | 4.75 in. OD 3.75 in. ID |
|  | 4.5 in. Sonic Bit LHSL Full Face, Para | 215779 | 4.88 in. OD |

S-S (Shoulder to Shoulder)
CC (Carbide Composite)

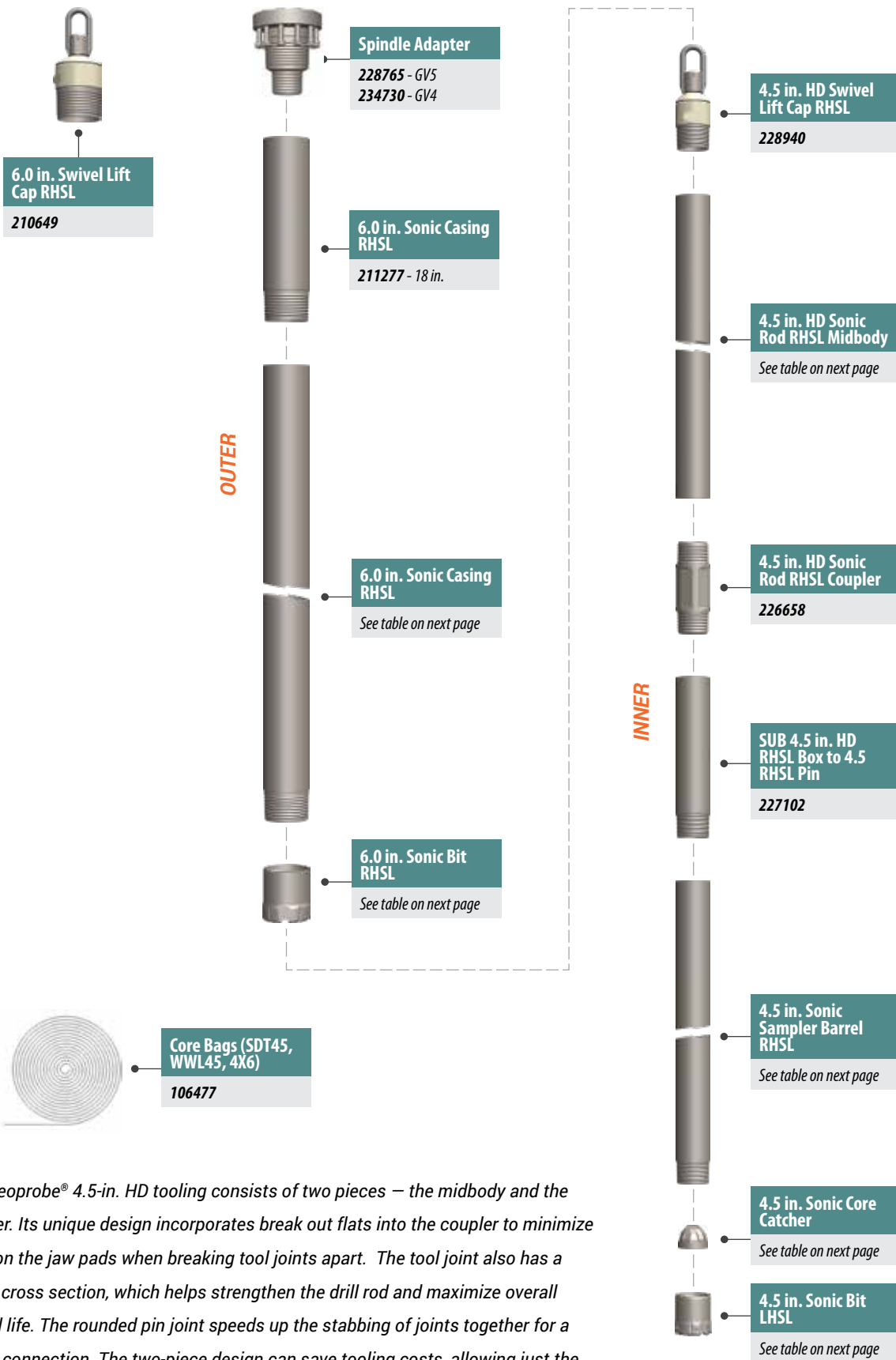





The Geoprobe® 4.5-in. HD tooling consists of two pieces – the midbody and the coupler. Its unique design incorporates break out flats into the coupler to minimize wear on the jaw pads when breaking tool joints apart. The tool joint also has a larger cross section, which helps strengthen the drill rod and maximize overall thread life. The rounded pin joint speeds up the stabbing of joints together for a faster connection. The two-piece design can save tooling costs, allowing just the coupler to be replaced if the threads are damaged.

OUTER

6.0 in. Sonic Casing RHSL

| Components | MN | Length | Weight | OD | ID |
|---|--------|---------|------------|---------|----------|
|  | 210799 | 120 in. | 225 lbs. | 6.0 in. | 5.25 in. |
| | 210648 | 60 in. | 112.5 lbs. | | |
| | 211174 | 24 in. | 45 lbs. | | |
| | 211277 | 18 in. | 33.75 lbs. | | |
| | 212350 | 12 in. | 22.5 lbs. | | |
| | 212351 | 6 in. | 11.25 lbs. | | |

Bits



| Components | Part | MN | Notes |
|---|---|--------|----------------------------|
|  | 6.0 in. Sonic Bit RHSL, Dome | 210749 | 6.38 in. OD 5.02 in. ID |
|  | 6.0 in. Sonic Bit RHSL, Para | 213325 | 6.45 in. OD 5.02 in. ID |
|  | 6.0 in. Sonic Bit RHSL, Dome Hardfaced NEW | 237966 | 6.38 in. OD 5.02 in. ID |
|  | 6.0 in. Sonic Bit RHSL, Para Hardfaced NEW | 237967 | 6.45 in. OD 5.02 in. ID |

COMBINED COMPONENTS







Spindle Adapters

| Components | Part | MN | Notes |
|---|--|--------|-----------|
|  | GV5 ADPT 6.0 RHSL x 4.5 HD x 3.5 LHSL | 228765 | HD |
|  | GV4 ADPT 6.0 RHSL x 4.5 HD x 3.5 LHSL NEW | 234730 | HD |

Subs / Adapters

| Components | Part | MN | Notes |
|---|---------------------------|--------|---------------------------|
|  | 4.5 HD Box x 6.0 RHSL Pin | 226740 | 4.00 in. S-S |
|  | 4.5 HD Pin x 6.0 RHSL Box | 226741 | 8.50 in. S-S |
|  | 4.5 HD Box x 4.5 HD Pin | 229271 | 4.00 in. S-S Sub Saver |

Accessories



| Components | Part | MN | Notes |
|---|----------------------------------|--------|----------------------|
|  | 6.0 in. Threadless Pin Sand Slip | 216182 | |
|  | 6.0 in. Swivel Lift Cap RHSL | 210649 | Pin |
|  | 4.5 in. HD Swivel Lift Cap RHSL | 228940 | Pin |
|  | Rod Wiper Donut | 600624 | 6.0 in. |
|  | Rod Wiper Donut | 600448 | 4.5 in. |
|  | Core Bags (SDT45, WWL45, 4X6) | 106477 | 8 in. flat x 725 ft. |
|  | Thread Compound | 600729 | 1 Gallon |

INNER

4.5 in. HD Sonic Rod RHSL Midbody

| Components | MN | Length | Weight | OD | ID |
|---|--------|---------|-----------|---------|----------|
|  | 226643 | 120 in. | 189 lbs. | 4.5 in. | 3.75 in. |
| | 226634 | 60 in. | 94.5 lbs. | | |
| | 226641 | 24 in. | 37.8 lbs. | | |



Coupler / Subs

| Components | Part | MN | Notes |
|---|---|--------|-------------------------|
|  | 4.5 in. HD Sonic Rod RHSL Coupler | 226658 | 4.5 in. OD 3.0 in ID |
|  | SUB 4.5 in. HD RHSL Box to 4.5 RHSL Pin | 227102 | |









Sampler Barrel

| Components | Part | MN | Notes |
|---|-----------------------------------|--------|--------|
|  | 4.5 in. Sonic Sampler Barrel RHSL | 227183 | 60 in. |
| | | 223849 | 12 in. |
| | | 229565 | 6 in. |

Core Catchers

| Components | Part | MN | Notes |
|--|----------------------------|--------|-----------|
|  | 4.5 in. Sonic Core Catcher | 227260 | RH |
|  | 4.5 in. Sonic Core Catcher | 231159 | RH, Short |

Bits

| Components | Part | MN | Notes |
|--|--|--------|----------------------------|
|  | 4.5 in. Sonic Bit RHSL, Dome | 229575 | 4.88 in. OD 3.53 in. ID |
|  | 4.5 in. Sonic Bit RHSL, Para | 229941 | 4.95 in. OD 3.52 in. ID |
|  | 4.5 in. Sonic Bit RHSL, Dome Hardfaced NEW | 237958 | 4.88 in. OD 3.53 in. ID |
|  | 4.5 in. Sonic Bit RHSL, Para Hardfaced NEW | 237959 | 4.95 in. OD 3.52 in. ID |
|  | 4.5 in. Sonic Bit RHSL Undercut, Para | 227193 | 4.90 in. OD 3.32 in. ID |
|  | 4.5 in. Sonic Bit RHSL Undercut, Para Hardfaced NEW | 237962 | 4.90 in. OD 3.32 in. ID |
|  | 4.5 in. Sonic Bit RHSL Undercut ID Carbide, Para | 229606 | 4.90 in. OD 3.15 in. ID |
|  | 4.5 in. Sonic Bit RHSL Full Face, Para | 229954 | 4.88 in. OD |

S-S (Shoulder to Shoulder)

4.5 in. HD Sonic Rodsgeoprobe.com/4.5-sonic-hd

Go "Behind the Design" to find out the engineering perspective on our HD sonic tooling.

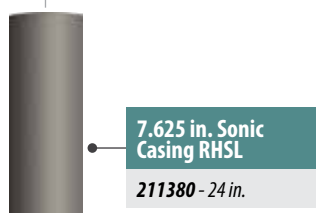
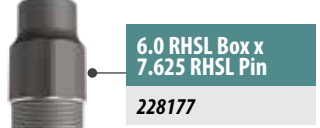

OUTER

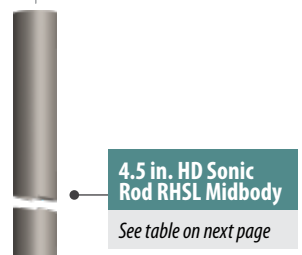
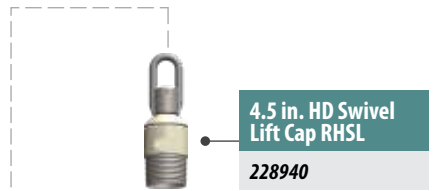
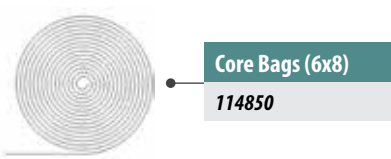

Note:
4.5 in. LHSL tooling can be used for inner rods

INNER

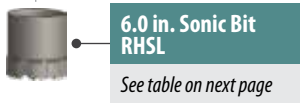
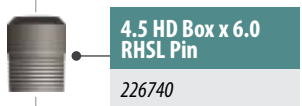
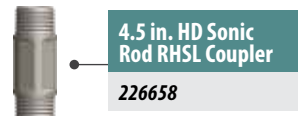

Geoprobe Systems® 6x8 sonic sampling provides the operator a larger diameter sample if desired, but this casing combination is typically used to provide a larger hole, such as to set a monitoring well.

OUTER**7.625 in. Sonic Casing RHSL**

| Components | MN | Length | Weight | OD | ID |
|---|--------|---------|------------|-----------|-----------|
|  | 211216 | 120 in. | 337 lbs. | 7.625 in. | 6.765 in. |
| | 211055 | 60 in. | 168.5 lbs. | | |
| | 211380 | 24 in. | 67.4 lbs. | | |

Bits

| Components | Part | MN | Notes |
|---|---------------------------------------|--------|----------------------------|
|  | 7.625 in. Sonic Bit RHSL, Dome | 211056 | 8.07 in. OD 6.73 in. ID |
| | 7.625 in. Sonic Bit RHSL CC | 226012 | 7.63 in. OD 6.88 in. ID |

COMBINED COMPONENTS**Spindle Adapters**

| Components | Part | MN | Notes |
|--|--|--------|------------------------------|
|  | GV5 ADPT 6.0 RHSL x 4.5 LHSL x 3.5 LHSL | 218880 | |
| | GV5 ADPT 6.0 RHSL x 4.5 HD x 3.5 LHSL | 228765 | HD |
| | GV5 ADPT 7.625 RHSL | 229302 | Bolt On |
| | GV4 ADPT 6.0 RHSL x 4.5 LHSL x 3.5 LHSL | 211278 | |
| | GV4 ADPT 6.0 RHSL x 4.5 HD x 3.5 LHSL | 234730 | HD |
| | GV4 ADPT 7.625 RHSL | 211060 | Bolt On, Requires: 211154 |

Subs / Adapters

| Components | Part | MN | Notes |
|---|--------------------------------------|--------|---------------------|
|  | 6.0 RHSL Box x 7.625 RHSL Pin | 228177 | 10.50 in. S-S, Long |
| | 6.0 RHSL Box x 7.625 RHSL Pin | 212218 | 4.00 in. S-S |
| | 4.5 HD Box x 6.0 RHSL Pin | 226740 | 4.00 in. S-S |
| | 4.5 HD Pin x 6.0 RHSL Box | 226741 | 8.50 in. S-S |
| | 4.5 LHSL Box x 6.0 LHSL Pin | 211647 | 11.00 in. S-S |

Accessories

| Components | Part | MN | Notes |
|---|--|-----------------------|-----------|
|  | 7.625 in. Lift Cap RHSL | 211301 | Pin |
| | 6.0 in. Swivel Lift Cap RHSL | 210649 | Pin |
| | 4.5 in. HD Swivel Lift Cap RHSL | 228940 | Pin |
| | 4.5 in. Swivel Lift Cap LHSL | 210606 | Pin |
| | Rod Wiper Donut | 106478 | 7.625 in. |
| 600624 | | 6.0 in. | |
| 600448 | | 4.5 in. | |
| Core Bags (6x8) | 114850 | 10 in. flat x 725 ft. | |
| Thread Compound | 600729 | 1 Gallon | |

S-S (Shoulder to Shoulder)

INNER**4.5 in. HD**

| Components | MN | Length | Weight | OD | ID |
|---|--------|---------|-----------|---------|----------|
|  | 226643 | 120 in. | 189 lbs. | 4.5 in. | 3.75 in. |
| | 226634 | 60 in. | 94.5 lbs. | | |
| | 226641 | 24 in. | 37.8 lbs. | | |

| Components | Part | MN | Notes |
|---|--|--------|-------------------------|
|  | 4.5 in. HD Sonic Rod RHSL Coupler | 226658 | 4.5 in. OD 3.0 in ID |

4.5 in. Sonic Casing LHSL

| Components | MN | Length | Weight | OD | ID |
|---|--------|---------|-----------|---------|----------|
|  | 210172 | 120 in. | 165 lbs. | 4.5 in. | 3.75 in. |
| | 210495 | 60 in. | 82.5 lbs. | | |
| | 210563 | 24 in. | 33 lbs. | | |
| | 210602 | 12 in. | 16.5 lbs. | | |

6.0 in. Sonic Casing RHSL

| Components | MN | Length | Weight | OD | ID |
|---|--------|---------|------------|---------|----------|
|  | 210979 | 120 in. | 225 lbs. | 6.0 in. | 5.25 in. |
| | 210648 | 60 in. | 112.5 lbs. | | |
| | 211174 | 24 in. | 45 lbs. | | |
| | 211277 | 18 in. | 33.75 lbs. | | |
| | 212350 | 12 in. | 22.5 lbs. | | |
| | 212351 | 6 in. | 11.25 lbs. | | |







Sampler Barrel LHSL

| Components | Part | MN | Notes |
|---|--|--------|--------|
|  | 6.0 in. Sonic Sampler Barrel LHSL | 211383 | 60 in. |
| | 6.0 in. Sonic Sampler Barrel LHSL | 222663 | 12 in. |

Core Catchers

| Components | Part | MN | Notes |
|---|-----------------------------------|--------|-----------|
|  | 6.0 in. Sonic Core Catcher | 211107 | RH |
| | 6.0 in. Sonic Core Catcher | 231193 | RH, Short |
| | 6.0 in. Sonic Core Catcher | 211746 | LH |
| | 6.0 in. Sonic Core Catcher | 231202 | LH, Short |

Bits

| Components | Part | MN | Notes |
|---|--|--------|----------------------------|
|  | 6.0 in. Sonic Bit RHSL, Dome | 210749 | 6.38 in. OD 5.02 in. ID |
| | 6.0 in. Sonic Bit RHSL, Para | 213325 | 6.45 in. OD 5.02 in. ID |
|  | 6.0 in. Sonic Bit RHSL, Dome Hardfaced | 237966 | 6.38 in. OD 5.02 in. ID |
| | 6.0 in. Sonic Bit RHSL, Para Hardfaced | 237967 | 6.45 in. OD 5.02 in. ID |
|  | 6.0 in. Sonic Bit RHSL CC | 226017 | 6.00 in. OD 5.25 in. ID |
|  | 6.0 in. Sonic Bit RHSL Full Face, Para | 222884 | 6.35 in. OD |
|  | 6.0 in. Sonic Bit LHSL, Dome | 211409 | 6.38 in. OD 5.02 in. ID |
|  | 6.0 in. Sonic Bit LHSL ID Carbide, Dome | 216273 | 6.38 in. OD 4.71 in. ID |

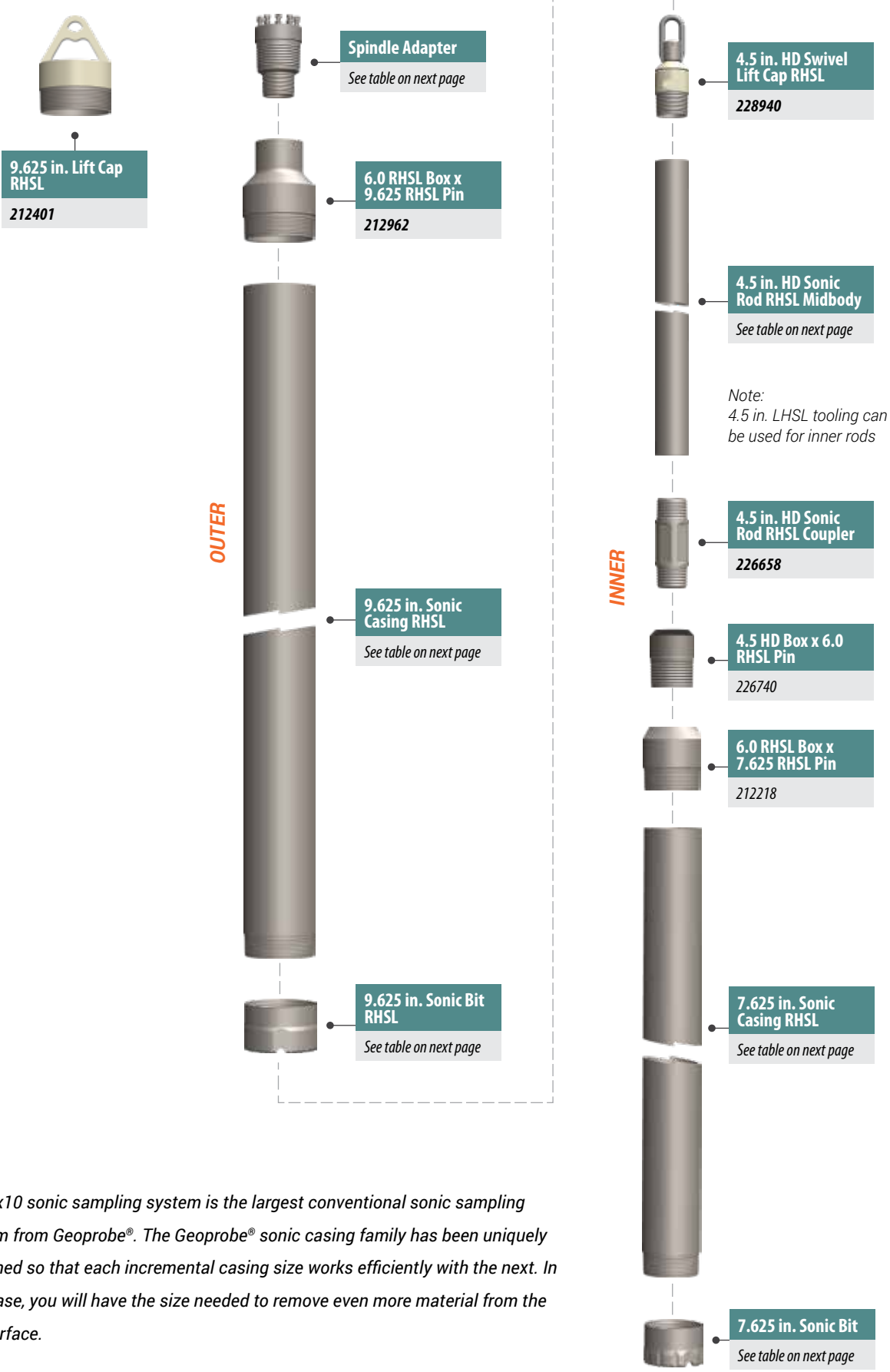

The 8x10 sonic sampling system is the largest conventional sonic sampling system from Geoprobe®. The Geoprobe® sonic casing family has been uniquely designed so that each incremental casing size works efficiently with the next. In this case, you will have the size needed to remove even more material from the subsurface.

OUTER

9.625 in. Sonic Casing RHSL





| Components | MN | Length | Weight | OD | ID |
|---|--------|---------|------------|-----------|-----------|
|  | 212297 | 120 in. | 435 lbs. | 9.625 in. | 8.755 in. |
| | 215137 | 60 in. | 217.5 lbs. | | |
| | 212296 | 24 in. | 87 lbs. | | |

Bits



| Components | Part | MN | Notes |
|---|--------------------------------|--------|----------------------------|
|  | 9.625 in. Sonic Bit RHSL, Dome | 212298 | 9.90 in. OD 8.80 in. ID |
| | 9.625 in. Sonic Bit RHSL CC | 226010 | 9.63 in. OD 8.84 in. ID |

COMBINED COMPONENTS

Subs / Adapters

| Components | Part | MN | Notes |
|---|---------------------------------|--------|---------------------|
|  | 7.625 RHSL Box x 9.625 RHSL Pin | 212620 | 10.00 in. S-S |
| | 6.0 RHSL Box x 9.625 RHSL Pin | 212962 | 10.00 in. S-S |
|  | 6.0 RHSL Box x 7.625 RHSL Pin | 228177 | 10.50 in. S-S, Long |
| | 6.0 RHSL Box x 7.625 RHSL Pin | 212218 | 4.00 in. S-S |
|  | 4.5 HD Box x 6.0 RHSL Pin | 226740 | 4.00 in. S-S |
| | 4.5 HD Pin x 6.0 RHSL Box | 226741 | 8.50 in. S-S |
|  | 4.5 LHSL Box x 7.625 LHSL Pin | 212893 | 5.40 in. S-S |



Accessories

| Components | Part | MN | Notes |
|---|---------------------------------|--------|-----------|
|  | 9.625 in. Lift Cap RHSL | 212401 | Pin |
| | 7.625 in. Lift Cap RHSL | 211301 | Pin |
|  | 4.5 in. HD Swivel Lift Cap RHSL | 228940 | Pin |
| | 4.5 in. Swivel Lift Cap LHSL | 210606 | Pin |
|  | | 106768 | 9.625 in. |
| | | 106478 | 7.625 in. |
| | | 600624 | 6.0 in. |
| | | 600448 | 4.5 in. |
|  | Thread Compound | 600729 | 1 Gallon |

S-S (Shoulder to Shoulder)

INNER

4.5 in. HD

| Components | MN | Length | Weight | OD | ID |
|---|-----------------------------------|---------|-------------------------|---------|----------|
|  | 226643 | 120 in. | 189 lbs. | 4.5 in. | 3.75 in. |
| | 226634 | 60 in. | 94.5 lbs. | | |
| | 226641 | 24 in. | 37.8 lbs. | | |
| Components | Part | MN | Notes | | |
|  | 4.5 in. HD Sonic Rod RHSL Coupler | 226658 | 4.5 in. OD 3.0 in ID | | |

4.5 in. Sonic Casing LHSL

| Components | MN | Length | Weight | OD | ID |
|---|--------|---------|-----------|---------|----------|
|  | 210172 | 120 in. | 165 lbs. | 4.5 in. | 3.75 in. |
| | 210495 | 60 in. | 82.5 lbs. | | |
| | 210563 | 24 in. | 33 lbs. | | |
| | 210602 | 12 in. | 16.5 lbs. | | |



7.625 in. Sonic Casing RHSL

| Components | MN | Length | Weight | OD | ID |
|---|--------|---------|------------|-----------|-----------|
|  | 211216 | 120 in. | 337 lbs. | 7.625 in. | 6.765 in. |
| | 211055 | 60 in. | 168.5 lbs. | | |
| | 211380 | 24 in. | 67.4 lbs. | | |

Sampler Barrel LHSL





| Components | Part | MN | Notes |
|---|-------------------------------------|--------|--------|
|  | 7.625 in. Sonic Sampler Barrel LHSL | 215250 | 60 in. |

Bits

| Components | Part | MN | Notes |
|---|--------------------------------|--------|----------------------------|
|  | 7.625 in. Sonic Bit RHSL, Dome | 211056 | 8.07 in. OD 6.73 in. ID |
| | 7.625 in. Sonic Bit RHSL CC | 226012 | 7.63 in. OD 6.88 in. ID |
|  | 7.625 in. Sonic Bit LHSL, Dome | 215252 | 8.07 in. OD 6.73 in. ID |

COMBINED COMPONENTS

Spindle Adapters

| Components | Part | MN | Notes |
|---|---|--------|------------------------------|
|  | GV5 ADPT 6.0 RHSL x 4.5 LHSL x 3.5 LHSL | 218880 | |
| | GV5 ADPT 6.0 RHSL x 4.5 HD x 3.5 LHSL | 228765 | HD |
|  | GV5 ADPT 7.625 RHSL | 229302 | Bolt On |
|  | GV4 ADPT 6.0 RHSL x 4.5 LHSL x 3.5 LHSL | 211278 | |
| | GV4 ADPT 6.0 RHSL x 4.5 HD x 3.5 LHSL | 234730 | HD |
|  | GV4 ADPT 7.625 RHSL | 211060 | Bolt On, Requires: 211154 |

SDT45 5-ft. Interval Sonic Sampling

geoprobe.com/sdt45-5



785-825-1842

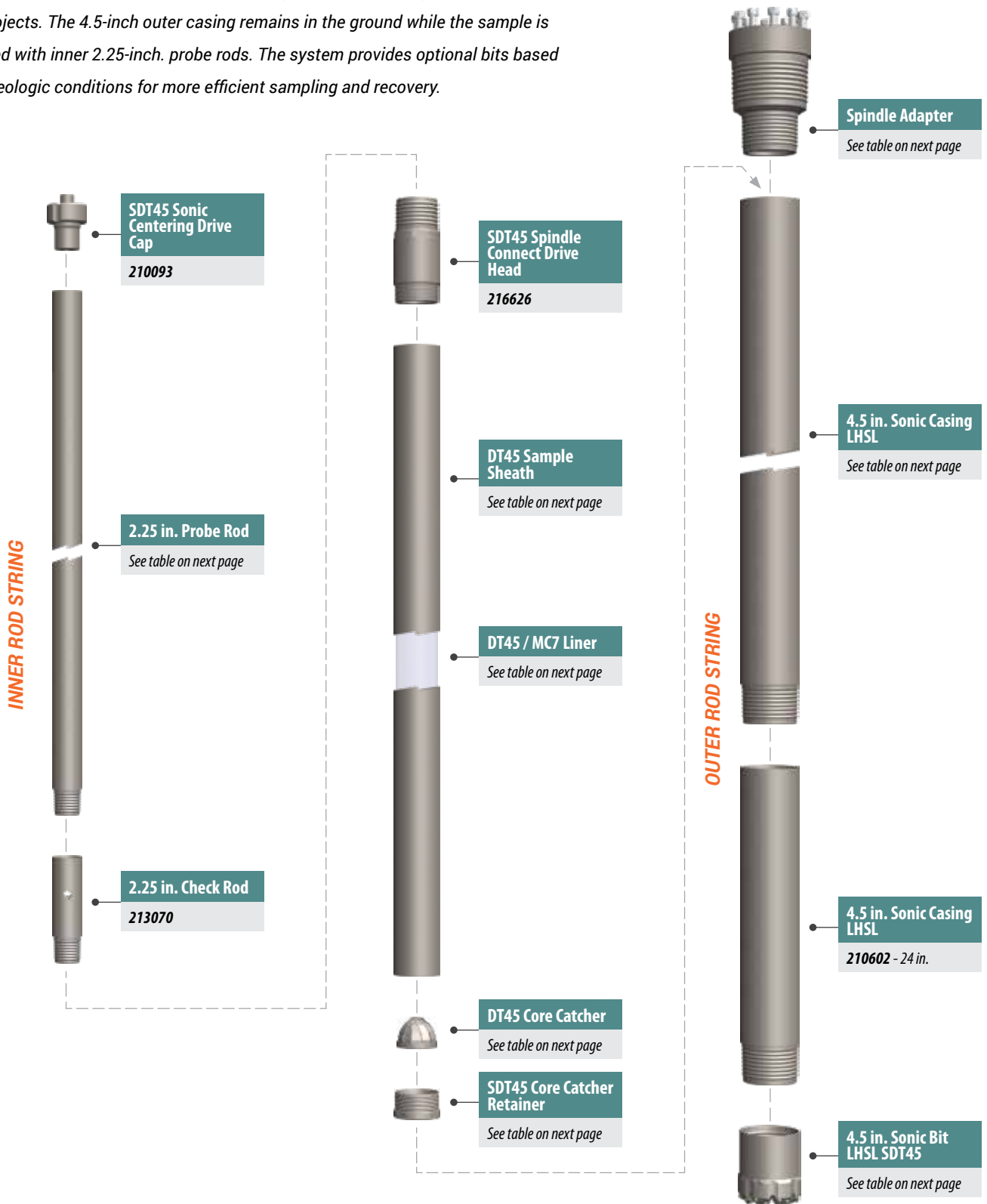

The versatile SDT45 system can be used for environmental sampling, varying types of well installations, cased hole applications, geotechnical borings, and exploration projects. The 4.5-inch outer casing remains in the ground while the sample is retrieved with inner 2.25-inch probe rods. The system provides optional bits based upon geologic conditions for more efficient sampling and recovery.





INNER ROD STRING**Centering Drive Cap**

| Components | Part | MN | Notes |
|---|---------------------------------|--------|-------|
|  | SDT45 Sonic Centering Drive Cap | 210093 | |

Probe Rods

| 2.25 in. Probe Rod | MN | Length | Weight | OD | ID |
|---|--------|--------|---|----------|---------|
|  | 204767 | 60 in. | 37.5 lbs. | 2.25 in. | 1.5 in. |
| | 204766 | 48 in. | 30 lbs. | | |
| | 206588 | 24 in. | 15 lbs. | | |
| | 204777 | 12 in. | 7.5 lbs. | | |
|  | 213070 | 6 in. | 2.25 in. Check Rod (Nylon Ball: 101120, Spring Pin: 106971) | | |

Spindle Connect Drive Heads

| Components | Part | MN | Notes |
|---|----------------------------------|--------|----------------|
|  | SDT45 Spindle Connect Drive Head | 216626 | |
|  | WWL45 Spindle Connect Drive Head | 220196 | Endless Thread |









Sample Sheath

| Components | Part | MN | Notes |
|--|--------------------|--------|------------------------|
|  | DT45 Sample Sheath | 205762 | 72 in. |
| | | 231581 | 72 in., Endless Thread |
| | | 205761 | 60 in. |
| | | 205760 | 48 in. |



Liners

| Components | Part | MN | Notes |
|---|------------------|--------|---|
|  | DT45 / MC7 Liner | 600720 | 72 in., PVC, Built to Order, Quantity: 18 |
| | DT45 / MC7 Liner | 600719 | 60 in., PVC Quantity: 18 |
| | DT45 / MC7 Liner | 600721 | 48 in., PVC Quantity: 18 |

Core Catchers / Retainers

| Components | Part | MN | Notes |
|---|---|--------|----------------------------|
|  | DT45 Liner Retainer | 212520 | |
|  | SDT45 Sonic Core Catcher | 216554 | |
|  | DT45 Core Catcher | 226134 | Short |
|  | SDT45 Core Catcher Retainer | 218304 | Asm |
|  | SDT45 Core Catcher Retainer | 217894 | Asm, Endless Thread |
|  | SDT45 Core Catcher Retainer | 226147 | Asm, Endless Thread, Short |
|  | SDT45 Core Catcher Retaining Ring | 217634 | |
|  | DT45 Retainer / MC7 Cutting Shoe Wrench | 205773 | |



OUTER ROD STRING**Spindle Adapters**

| Components | Part | MN | Notes |
|--|---|--------|-------|
|  | GV5 ADPT 6.0 RHSL x 4.5 LHSL x 3.5 LHSL | 218880 | |
|  | GV4 ADPT 6.0 RHSL x 4.5 LHSL x 3.5 LHSL | 211278 | |

4.5 in. Sonic Casing LHSL

| Components | MN | Length | Weight | OD | ID |
|---|--------|--------|-----------|---------|----------|
|  | 210495 | 60 in. | 82.5 lbs. | 4.5 in. | 3.75 in. |
| | 210563 | 24 in. | 33 lbs. | | |
| | 210602 | 12 in. | 16.5 lbs. | | |

Bits

| Components | Part | MN | Notes |
|--|------------------------------------|--------|----------------------------|
|  | 4.5 in. Sonic Bit LHSL SDT45, Dome | 226395 | 4.93 in. OD 2.65 in. ID |
|  | 4.5 in. Sonic Bit LHSL SDT45, Para | 210566 | 4.93 in. OD 2.65 in. ID |

Subs / Adapters

| Components | Part | MN | Notes |
|---|-----------------------------|--------|---------------------------|
|  | 4.5 LHSL Box x 4.5 LHSL Pin | 212679 | 4.00 in. S-S Sub Saver |

COMBINED COMPONENTS**Replacement Parts / Accessories**

| Components | Part | MN | Notes |
|--|--|--------|----------------------|
|  | 1.25 in. Nylon Ball | 101120 | |
|  | SDT45 Center Rod Guide | 216614 | |
|  | 4.5 in. Swivel Lift Cap LHSL | 210606 | Pin |
|  | 2.25 in. Spring Assisted Swivel Lift Cap | 217609 | Pin |
|  | Rod Wiper Donut | 600448 | 4.5 in. |
|  | DT45/MC7 Liner Cutter | 206987 | |
|  | Liner Cutter Replacement Blades | 600985 | Quantity: 5 |
|  | Core Bags (SDT45, WWL45, 4X6) | 106477 | 8 in. flat x 725 ft. |
|  | Thread Compound | 600729 | 1 Gallon |

SDT45 10-ft. Interval Sonic Sampling

geoprobe.com/sdt45-10



785-825-1842

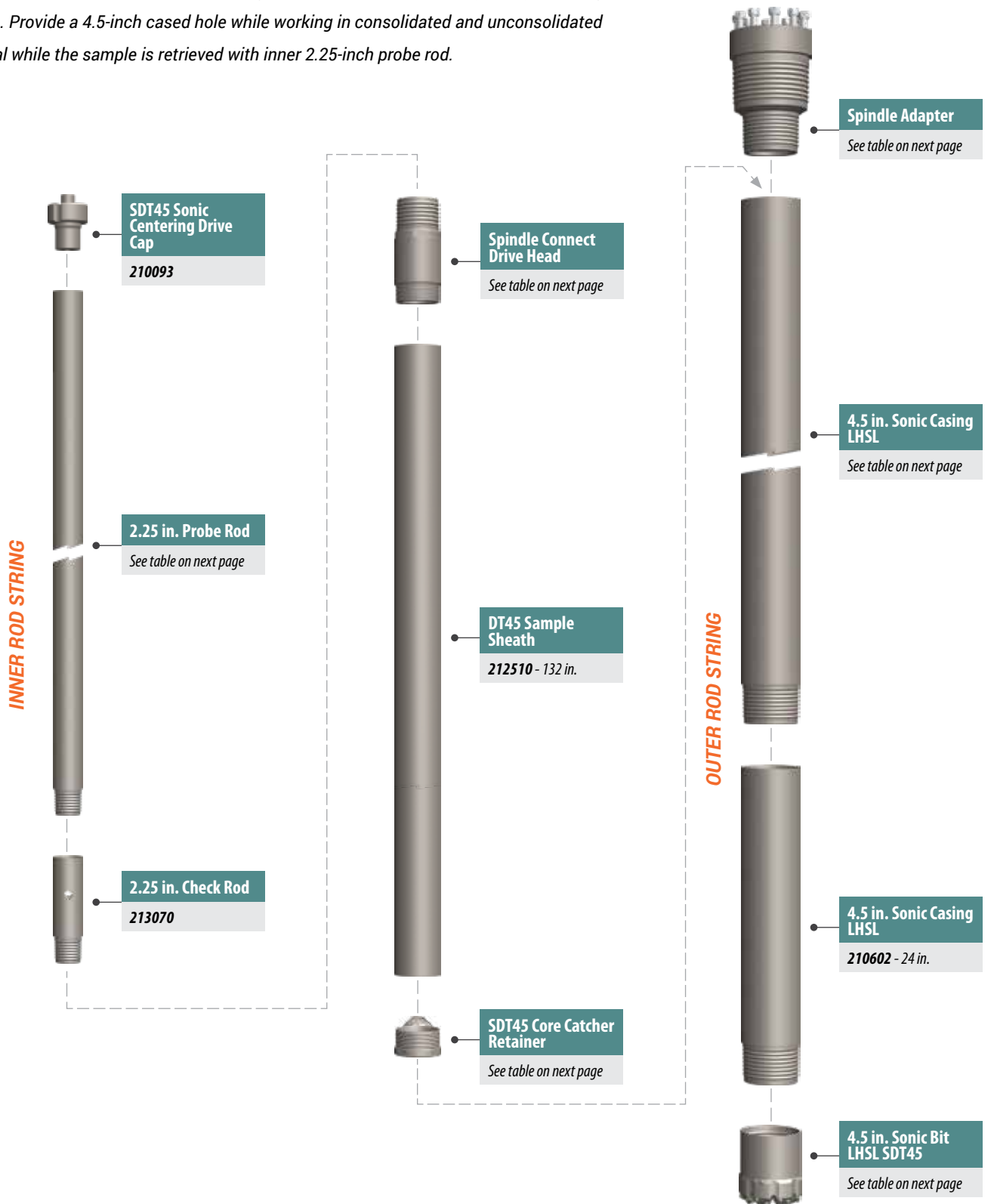

Save time and fatigue advancing an outer casing and inner soil sampler simultaneously using the unique and versatile Geoprobe Systems® Sonic Dual Tube 45 (SDT45) sampling system. Provide a 4.5-inch cased hole while working in consolidated and unconsolidated material while the sample is retrieved with inner 2.25-inch probe rod.





INNER ROD STRING*Centering Drive Cap*

| Components | Part | MN | Notes |
|---|---------------------------------|--------|-------|
|  | SDT45 Sonic Centering Drive Cap | 210093 | |

Probe Rods

| 2.25 in. Probe Rod | MN | Length | Weight | OD | ID |
|---|--------|--------|---------------------------|----------|---------|
|  | 204767 | 60 in. | 37.5 lbs. | 2.25 in. | 1.5 in. |
| | 204766 | 48 in. | 30 lbs. | | |
| | 206588 | 24 in. | 15 lbs. | | |
| | 204777 | 12 in. | 7.5 lbs. | | |
|  | 213070 | 6 in. | 2.25 in. Check Rod | | |







Spindle Connect Drive Heads

| Components | Part | MN | Notes |
|---|----------------------------------|--------|----------------|
|  | SDT45 Spindle Connect Drive Head | 216626 | |
|  | WWL45 Spindle Connect Drive Head | 220196 | Endless Thread |

Sample Sheath

| Components | Part | MN | Notes |
|--|--------------------|--------|-------------------------|
|  | DT45 Sample Sheath | 212510 | 132 in., Endless Thread |

Core Catchers / Retainers

| Components | Part | MN | Notes |
|---|---|--------|----------------------------|
|  | SDT45 Core Catcher Retainer | 218304 | Asm |
|  | SDT45 Core Catcher Retainer | 217894 | Asm, Endless Thread |
|  | SDT45 Core Catcher Retainer | 226147 | Asm, Endless Thread, Short |
|  | SDT45 Sonic Core Catcher | 216554 | |
|  | DT45 Core Catcher | 226134 | Short |
|  | SDT45 Core Catcher Retaining Ring | 217634 | |
|  | DT45 Retainer / MC7 Cutting Shoe Wrench | 205773 | |



OUTER ROD STRING*Spindle Adapters*

| Components | Part | MN | Notes |
|---|---|--------|-------|
|  | GV5 ADPT 6.0 RHSL x 4.5 LHSL x 3.5 LHSL | 218880 | |
| | GV4 ADPT 6.0 RHSL x 4.5 LHSL x 3.5 LHSL | 211278 | |

4.5 in. Sonic Casing LHSL

| Components | MN | Length | Weight | OD | ID |
|---|--------|---------|-----------|---------|----------|
|  | 210172 | 120 in. | 165 lbs. | 4.5 in. | 3.75 in. |
| | 210495 | 60 in. | 82.5 lbs. | | |
| | 210563 | 24 in. | 33 lbs. | | |
| | 210602 | 12 in. | 16.5 lbs. | | |



Bits

| Components | Part | MN | Notes |
|--|------------------------------------|--------|----------------------------|
|  | 4.5 in. Sonic Bit LHSL SDT45, Dome | 226395 | 4.93 in. OD 2.65 in. ID |
|  | 4.5 in. Sonic Bit LHSL SDT45, Para | 210566 | 4.93 in. OD 2.65 in. ID |

Subs / Adapters

| Components | Part | MN | Notes |
|--|-----------------------------|--------|---------------------------|
|  | 4.5 LHSL Box x 4.5 LHSL Pin | 212679 | 4.00 in. S-S Sub Saver |

COMBINED COMPONENTS*Replacement Parts / Accessories*

| Components | Part | MN | Notes |
|---|--|--------|----------------------|
|  | 1.25 in. Nylon Ball | 101120 | |
|  | SDT45 Center Rod Guide | 216614 | |
|  | 4.5 in. Swivel Lift Cap LHSL | 210606 | Pin |
|  | 2.25 in. Spring Assisted Swivel Lift Cap | 217609 | Pin |
|  | Rod Wiper Donut | 600448 | 4.5 in. |
|  | Core Bags (SDT45, WWL45, 4X6) | 106477 | 8 in. flat x 725 ft. |
|  | Thread Compound | 600729 | 1 Gallon |

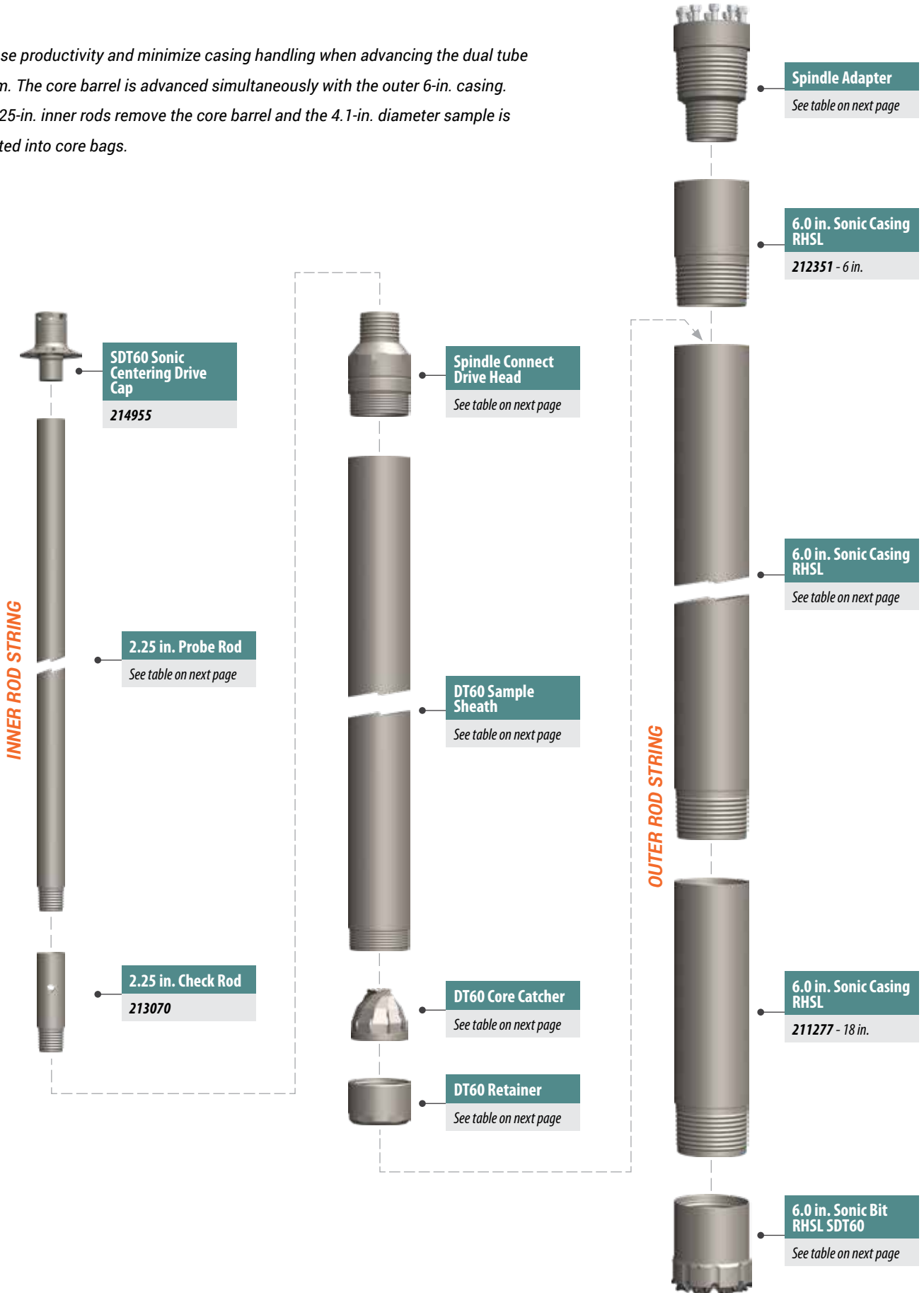

Increase productivity and minimize casing handling when advancing the dual tube system. The core barrel is advanced simultaneously with the outer 6-in. casing. Our 2.25-in. inner rods remove the core barrel and the 4.1-in. diameter sample is collected into core bags.





INNER ROD STRING*Centering Drive Cap*

| Components | Part | MN | Notes |
|---|--|--------|-------|
|  | SDT60 Sonic Centering Drive Cap | 214955 | |

Probe Rods

| 2.25 in. Probe Rod | MN | Length | Weight | OD | ID |
|---|--------|--------|---|----------|---------|
|  | 204767 | 60 in. | 37.5 lbs. | 2.25 in. | 1.5 in. |
| | 204766 | 48 in. | 30 lbs. | | |
| | 206588 | 24 in. | 15 lbs. | | |
| | 204777 | 12 in. | 7.5 lbs. | | |
|  | 213070 | 6 in. | 2.25 in. Check Rod (Nylon Ball: 101120, Spring Pin: 106971) | | |





Spindle Connect Drive Heads

| Components | Part | MN | Notes |
|---|---|--------|----------------|
|  | SDT60 Spindle Connect Drive Head | 212887 | |
|  | WWL60 Spindle Connect Drive Head | 223253 | Endless Thread |

Sample Sheath

| Components | Part | MN | Notes |
|--|------|--------|--------------------------|
|  | | 215043 | 72 in. |
| | | 215042 | 60 in. |
| | | 211621 | 12 in. |
| | | 213140 | 12 in. Endless Thread |

Core Catchers / Retainers

| Components | Part | MN | Notes |
|---|---------------------------------|--------|----------------|
|  | DT60 Core Catcher | 215016 | |
|  | SDT60 Sonic Core Catcher | 223224 | Short |
|  | DT60 Retainer | 211280 | |
|  | DT60 Retainer | 213139 | Endless Thread |
|  | DT60 Wrench | 208080 | |

OUTER ROD STRING*Spindle Adapters*

| Components | Part | MN | Notes |
|--|--|--------|-----------|
|  | GV5 ADPT 6.0 RHSL x 4.5 LHSL x 3.5 LHSL | 218880 | |
| | GV5 ADPT 6.0 RHSL x 4.5 HD x 3.5 LHSL | 228765 | HD |
| | GV4 ADPT 6.0 RHSL x 4.5 LHSL x 3.5 LHSL | 211278 | |
| | GV4 ADPT 6.0 RHSL x 4.5 HD x 3.5 LHSL | 234730 | HD |

6.0 in. Sonic Casing RHSL

| Components | MN | Length | Weight | OD | ID |
|---|--------|---------|------------|---------|----------|
|  | 210979 | 120 in. | 225 lbs. | 6.0 in. | 5.25 in. |
| | 210648 | 60 in. | 112.5 lbs. | | |
| | 211174 | 24 in. | 45 lbs. | | |
| | 211277 | 18 in. | 33.75 lbs. | | |
| | 212350 | 12 in. | 22.5 lbs. | | |
| | 212351 | 6 in. | 11.25 lbs. | | |

Bits

| Components | Part | MN | Notes |
|--|---|--------|----------------------------|
|  | 6.0 in. Sonic Bit RHSL SDT60, Dome | 226396 | 6.49 in. OD 4.10 in. ID |
| | 6.0 in. Sonic Bit RHSL SDT60, Para | 215162 | 6.49 in. OD 4.10 in. ID |

COMBINED COMPONENTS*Replacement Parts / Accessories*

| Components | Part | MN | Notes |
|---|---|--------|-----------------------|
|  | 1.25 in. Nylon Ball | 101120 | |
| | SDT60 Center Rod Guide | 218383 | |
|  | 6.0 in. Swivel Lift Cap RHSL | 210649 | Pin |
| | 2.25 in. Spring Assisted Swivel Lift Cap | 217609 | Pin |
|  | Rod Wiper Donut | 600624 | 6.0 in. |
|  | Core Bags (SDT60, WWL60) | 700127 | 9 in. flat x 1000 ft. |
|  | Thread Compound | 600729 | 1 Gallon |

Sonic SDT45 Weighted Wireline (WWL45)

geoprobe.com/dt45-wwl



785-825-1842

Designed to compliment standard SDT45 tooling, the core barrel uses a simple weight system to hold it in place at the bottom of the tool string rather than a mechanical latch. Makes for much faster trip times when utilized during 100-foot or greater depths in consolidated formations.



Core Bags (SDT45, WWL45, 4X6)
106477



WWL Connector Pin
220325



NWL WWL Overshot with Quick Change
223515

WWL Overshot Release Tube
220755

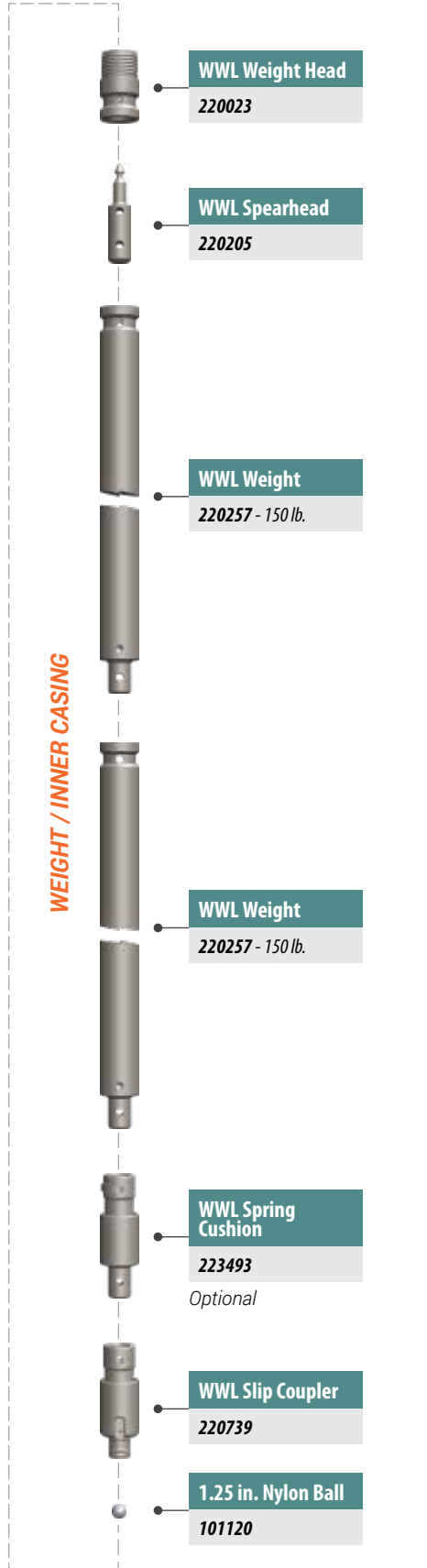

WWL Weight Head
220023

WWL Spearhead
220205

WWL Weight
220257 - 150 lb.

WWL Weight
220257 - 150 lb.

WWL Spring Cushion
223493
Optional

WWL Slip Coupler
220739

1.25 in. Nylon Ball
101120

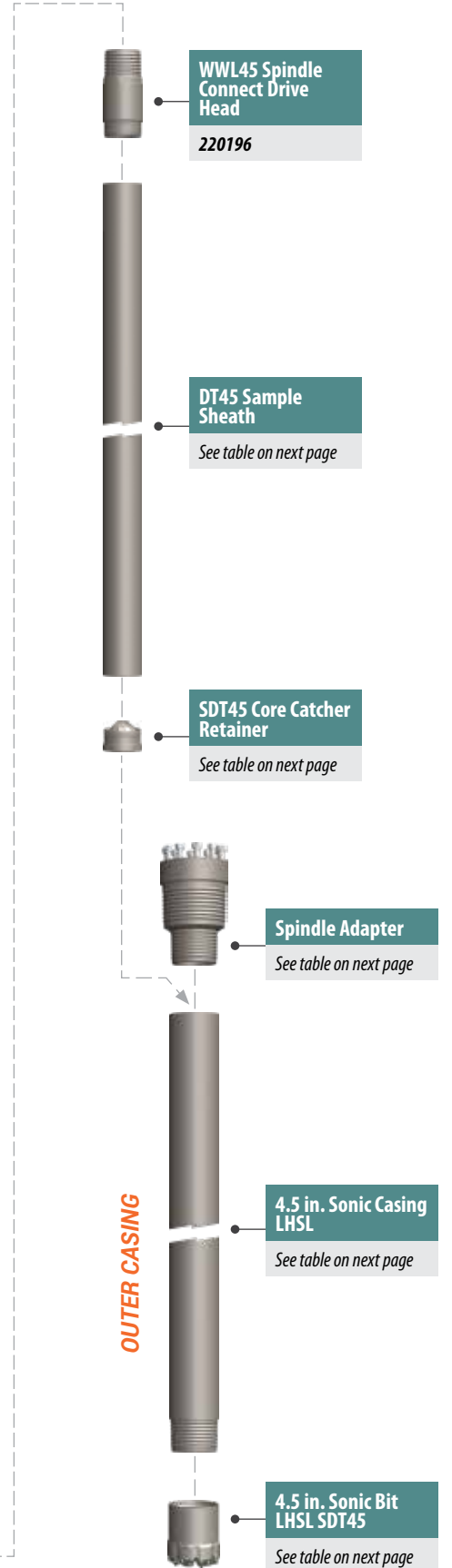

WWL45 Spindle Connect Drive Head
220196

DT45 Sample Sheath
See table on next page

SDT45 Core Catcher Retainer
See table on next page

Spindle Adapter
See table on next page

4.5 in. Sonic Casing LHSL
See table on next page

4.5 in. Sonic Bit LHSL SDT45
See table on next page

OVERSHOT*Accessories*

| Components | Part | MN | Notes |
|------------|------------------------------------|--------|-------|
| | NWL WWL Overshot with Quick Change | 223515 | |
| | WWL Overshot Release Tube | 220755 | |

WEIGHT / INNER CASING*Accessories*

| Components | Part | MN | Notes |
|----------------------------------|---------------------|----------------|-------------------------|
| | WWL Weight Head | 220023 | |
| | WWL Connector Pin | 220325 | |
| | WWL Spearhead | 220205 | |
| | WWL Weight | 220257 | 150 lb. |
| | WWL Spring Cushion | 223493 | Optional |
| | WWL Slip Coupler | 220739 | 2.25 in. Endless Thread |
| | 1.25 in. Nylon Ball | 101120 | |
| WWL45 Spindle Connect Drive Head | 220196 | Endless Thread | |

Sample Sheath

| Components | Part | MN | Notes |
|------------|--------------------|--------|-------------------------|
| | DT45 Sample Sheath | 212510 | 132 in., Endless Thread |
| | | 231581 | 72 in., Endless Thread |

Core Catchers / Retainers

| Components | Part | MN | Notes |
|------------|---|--------|----------------------------|
| | SDT45 Core Catcher Retainer | 217894 | Asm, Endless Thread |
| | SDT45 Core Catcher Retainer | 226147 | Asm, Endless Thread, Short |
| | SDT45 Sonic Core Catcher | 216554 | |
| | DT45 Core Catcher | 226134 | Short |
| | SDT45 Core Catcher Retaining Ring | 217634 | |
| | DT45 Retainer / MC7 Cutting Shoe Wrench | 205773 | |

OUTER ROD STRING*Spindle Adapters*

| Components | Part | MN | Notes |
|------------|---|--------|-------|
| | GV5 ADPT 6.0 RHSL x 4.5 LHSL x 3.5 LHSL | 218880 | |
| | GV4 ADPT 6.0 RHSL x 4.5 LHSL x 3.5 LHSL | 211278 | |

4.5 in. Sonic Casing LHSL

| Components | MN | Length | Weight | OD | ID |
|------------|--------|---------|-----------|---------|----------|
| | 210172 | 120 in. | 165 lbs. | 4.5 in. | 3.75 in. |
| | 210495 | 60 in. | 82.5 lbs. | | |
| | 210563 | 24 in. | 33 lbs. | | |
| | 210602 | 12 in. | 16.5 lbs. | | |

Bits

| Components | Part | MN | Notes |
|------------|------------------------------------|--------|----------------------------|
| | 4.5 in. Sonic Bit LHSL SDT45, Dome | 226395 | 4.93 in. OD 2.65 in. ID |
| | 4.5 in. Sonic Bit LHSL SDT45, Para | 210566 | 4.93 in. OD 2.65 in. ID |

Subs / Adapters

| Components | Part | MN | Notes |
|------------|-----------------------------|--------|------------------------|
| | 4.5 LHSL Box x 4.5 LHSL Pin | 212679 | 4.00 in. S-S Sub Saver |

COMBINED COMPONENTS*Accessories*

| Components | Part | MN | Notes |
|------------|--|--------|----------------------|
| | 4.5 in. Swivel Lift Cap LHSL | 210606 | Pin |
| | 3.5 in. Swivel Lift Cap LHSL | 209503 | Box |
| | 2.25 in. Spring Assisted Swivel Lift Cap | 217609 | Pin |
| | Rod Wiper Donut | 600448 | 4.5 in. |
| | DT45/MC7 Liner Cutter | 206987 | |
| | Liner Cutter Replacement Blades | 600985 | Quantity: 5 |
| | Core Bags (SDT45, WWL45, 4X6) | 106477 | 8 in. flat x 725 ft. |
| | Thread Compound | 600729 | 1 Gallon |

Sonic Weighted Wireline Overviewgeoprobe.com/wwl

This video looks at the speed of the sonic weighted wireline system.

Sonic SDT60 Weighted Wireline (WWL60)

geoprobe.com/dt60-wwl



785-825-1842

Designed and available exclusively through Geoprobe® and able for use under most sonic rigs, WWL60 makes for much faster trip times when utilized during 100-foot or greater depths in consolidated formations. Complimenting standard SDT60 tooling, the core barrel uses a weight system to hold it in place at the bottom of the tool string rather than a mechanical latch.



Core Bags (SDT60, WWL60)
700127



WWL Connector Pin
220325



OVERSHOT

NWL WWL Overshot with Quick Change
223515

WWL Overshot Release Tube
220755

WWL60 Overshot Centralizer
223518

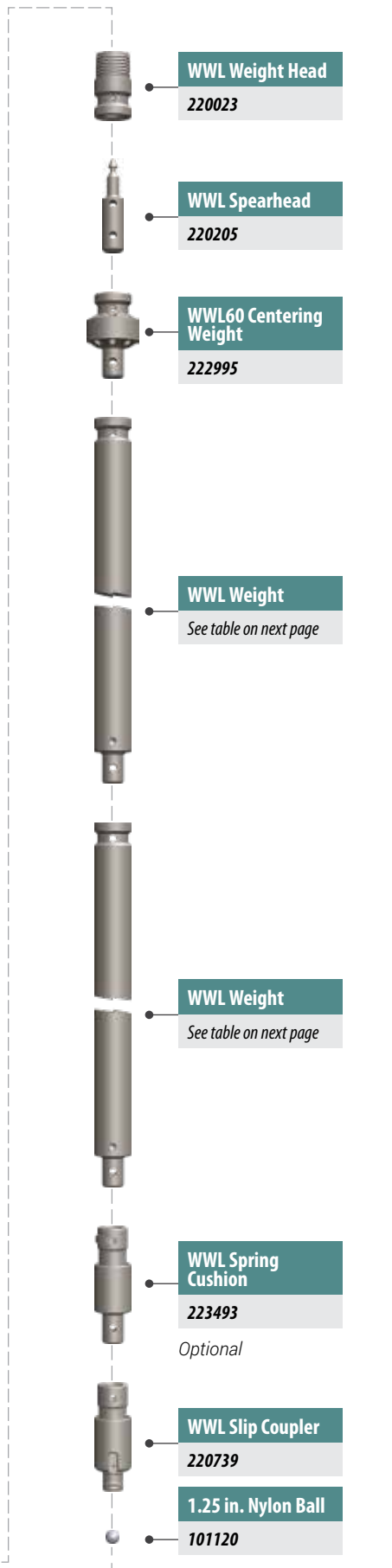

WWL Weight Head
220023

WWL Spearhead
220205

WWL60 Centering Weight
222995

WWL Weight
See table on next page

WWL Weight
See table on next page

WWL Spring Cushion
223493
Optional

WWL Slip Coupler
220739

1.25 in. Nylon Ball
101120

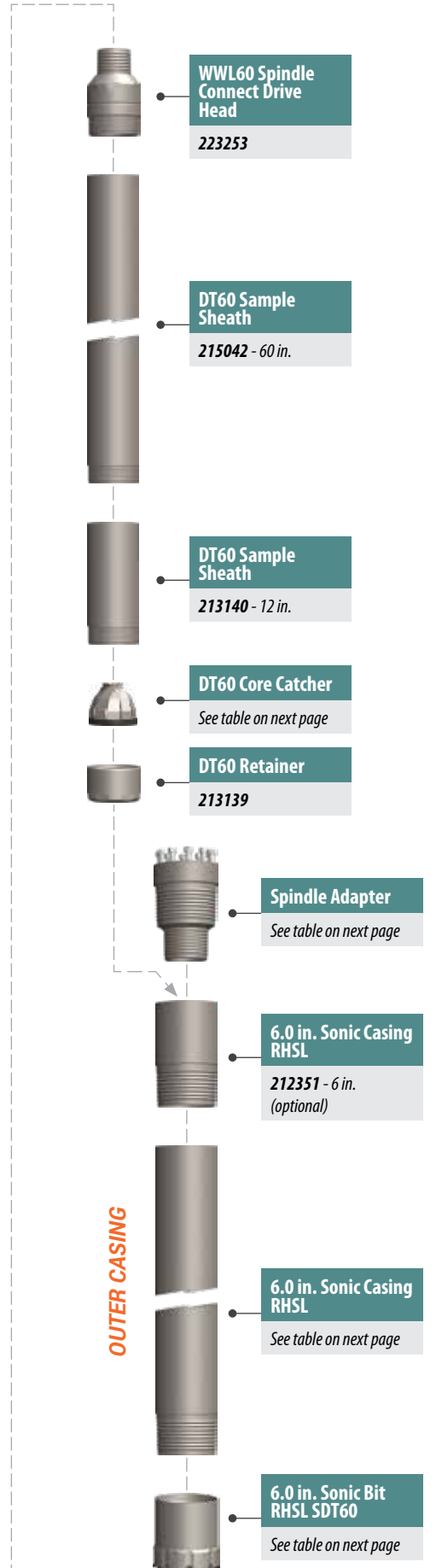

WWL60 Spindle Connect Drive Head
223253

DT60 Sample Sheath
215042 - 60 in.

DT60 Sample Sheath
213140 - 12 in.

DT60 Core Catcher
See table on next page

DT60 Retainer
213139

Spindle Adapter
See table on next page



6.0 in. Sonic Casing RHSL
212351 - 6 in. (optional)

6.0 in. Sonic Casing RHSL
See table on next page







6.0 in. Sonic Bit RHSL SDT60
See table on next page

OUTER CASING

OVERSHOT*Accessories*

| Components | Part | MN | Notes |
|---|------------------------------------|--------|-------|
|  | NWL WWL Overshot with Quick Change | 223515 | |
|  | WWL60 Overshot Centralizer | 223518 | |
|  | WWL Overshot Release Tube | 220755 | |





WEIGHT / INNER CASING*Accessories*

| Components | Part | MN | Notes |
|---|----------------------------------|--------|--------------------------|
|  | WWL Weight Head | 220023 | |
|  | WWL Connector Pin | 220325 | |
|  | WWL Spearhead | 220205 | |
|  | WWL60 Centering Weight | 222995 | |
|  | WWL Weight | 220257 | 150 lb. |
|  | WWL Weight | 223797 | 300 lb. |
|  | WWL Spring Cushion | 223493 | Optional |
|  | WWL Slip Coupler | 220739 | 2.25 in., endless thread |
|  | 1.25 in. Nylon Ball | 101120 | |
|  | WWL60 Spindle Connect Drive Head | 223253 | Endless Thread |





Sample Sheath

| Components | Part | MN | Notes |
|---|--------------------|--------|------------------------|
|  | DT60 Sample Sheath | 215042 | 60 in. |
| | | 213140 | 12 in., Endless Thread |

Core Catchers / Retainers

| Components | Part | MN | Notes |
|---|--------------------------|--------|----------------|
|  | DT60 Core Catcher | 215016 | |
|  | SDT60 Sonic Core Catcher | 223224 | Short |
|  | DT60 Retainer | 213139 | Endless Thread |
|  | DT60 Wrench | 208080 | |



OUTER ROD STRING*Spindle Adapters*

| Components | Part | MN | Notes |
|--|---|--------|-------|
|  | GV5 ADPT 6.0 RHSL x 4.5 LHSL x 3.5 LHSL | 218880 | |
|  | GV5 ADPT 6.0 RHSL x 4.5 HD x 3.5 LHSL | 228765 | HD |
|  | GV4 ADPT 6.0 RHSL x 4.5 LHSL x 3.5 LHSL | 211278 | |
|  | GV4 ADPT 6.0 RHSL x 4.5 HD x 3.5 LHSL | 234730 | HD |

6.0 in. Sonic Casing RHSL

| Components | MN | Length | Weight | OD | ID |
|---|--------|---------|------------|---------|----------|
|  | 210979 | 120 in. | 225 lbs. | 6.0 in. | 5.25 in. |
| | 210648 | 60 in. | 112.5 lbs. | | |
| | 211174 | 24 in. | 45 lbs. | | |
| | 211277 | 18 in. | 33.75 lbs. | | |
| | 212350 | 12 in. | 22.5 lbs. | | |
| | 212351 | 6 in. | 11.25 lbs. | | |

Bits

| Components | Part | MN | Notes |
|---|------------------------------------|--------|----------------------------|
|  | 6.0 in. Sonic Bit RHSL SDT60, Dome | 226396 | 6.49 in. OD 4.10 in. ID |
|  | 6.0 in. Sonic Bit RHSL SDT60, Para | 215162 | 6.49 in. OD 4.10 in. ID |

COMBINED COMPONENTS*Accessories*

| Components | Part | MN | Notes |
|--|--|--------|-----------------------|
|  | 6.0 in. Swivel Lift Cap RHSL | 210649 | Pin |
|  | 3.5 in. Swivel Lift Cap LHSL | 209503 | Box |
|  | 2.25 in. Spring Assisted Swivel Lift Cap | 217609 | Pin |
|  | Rod Wiper Donut | 600624 | 6.0 in. |
|  | Core Bags (SDT60, WWL60) | 700127 | 9 in. flat x 1000 ft. |
|  | Thread Compound | 600729 | 1 Gallon |

Sonic Weighted Wireline Overviewgeoprobe.com/wwl

See how the sonic weighted wireline system makes trip out times much faster than traditional sonic sampling.

SDW45 - Sonic Double Wall 4.5 in.

geoprobe.com/sdw45

SDW45 method allows the water to flow around the sample sheath and exit the water ports on the bit face, leaving the sample core unaffected. Effective tooling system designed to obtain confirmatory rock or bedrock samples at the end of a boring, whether using sonic 4x6 or SDT45 or used in place of traditional sonic dual tube system when angled drilling is required.

INNER (RH or LH Options)

- 4.5 in. HD Sonic Rod RHSL Midbody
See table on next page
- 4.5 in. HD Sonic Rod RHSL Coupler
226658
- Sub Saver
See table on next page
- SDT45 Sonic Centering Drive Cap
210093
- 2.25 in. Check Rod
213070
- Spindle Connect Drive Head
See table on next page
- DT45 Sample Sheath
See table on next page
- DT45 / MC7 Liner
See table on next page
- DT45 Core Catcher
See table on next page
- Retainer
See table on next page

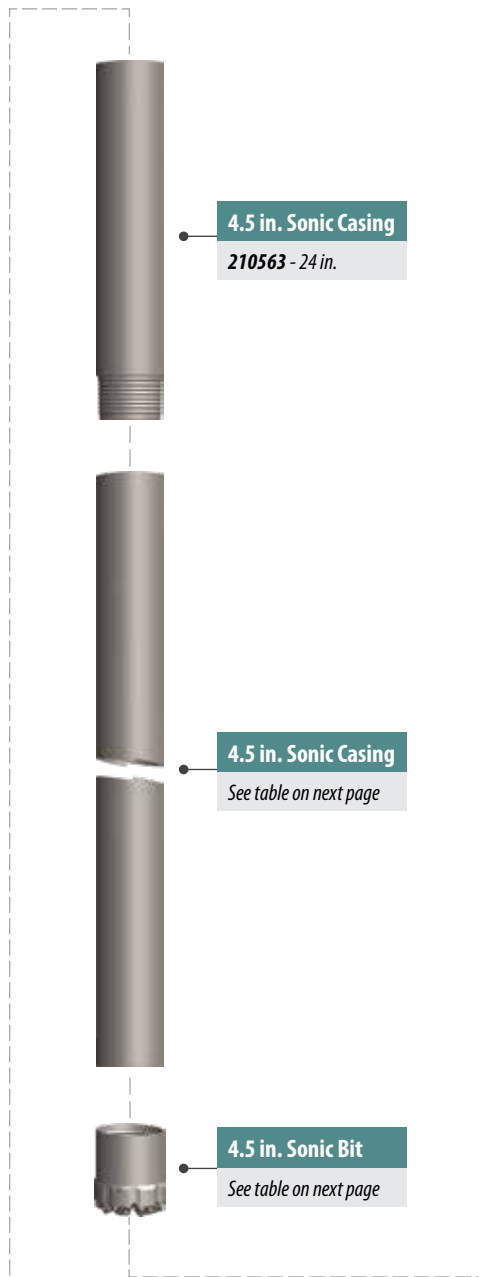





SDW Overview

geoprobe.com/sdw45

OUTER

- Spindle Adapter
See table on next page
- 6.0 in. Sonic Casing RHSL
211277 - 18 in.
- 6.0 in. Sonic Casing RHSL
See table on next page
- 6.0 in. Sonic Bit RHSL
See table on next page

INNER**Accessories**

| Components | Part | MN | Notes |
|---|----------------------------------|--------|----------------|
|  | SDT45 Sonic Centering Drive Cap | 210093 | |
|  | 2.25 in. Check Rod | 213070 | 6 in. |
|  | SDT45 Spindle Connect Drive Head | 216626 | |
|  | WWL45 Spindle Connect Drive Head | 220196 | Endless Thread |









Sample Sheath

| Components | Part | MN | Notes |
|---|--------------------|--------|-------------------------|
|  | DT45 Sample Sheath | 212510 | 132 in., Endless Thread |
| | | 205762 | 72 in. |
| | | 231581 | 72 in., Endless Thread |
| | | 205761 | 60 in. |
| | | 205760 | 48 in. |

Liners

| Components | Part | MN | Notes |
|---|------------------|--------|--------------------------------------|
|  | DT45 / MC7 Liner | 600720 | 72 in., PVC, Built to Order, Qty: 18 |
| | | 600719 | 60 in., PVC, Qty: 18 |
| | | 600721 | 48 in., PVC, Qty: 18 |

Core Catchers / Retainers

| Components | Part | MN | Notes |
|---|---|--------|----------------------------|
|  | DT45 Liner Retainer | 212520 | |
|  | SDT45 Sonic Core Catcher | 216554 | |
|  | DT45 Core Catcher | 226134 | Short |
|  | SDT45 Core Catcher Retainer | 218304 | Asm |
|  | SDT45 Core Catcher Retainer | 217894 | Asm, Endless Thread |
|  | SDT45 Core Catcher Retainer | 226147 | Asm, Endless Thread, Short |
|  | SDT45 Core Catcher Retaining Ring | 217634 | |
|  | DT45 Retainer / MC7 Cutting Shoe Wrench | 205773 | |





4.5 in. Sonic Casing LHSL

| Components | MN | Length | Weight | OD | ID |
|---|--------|---------|-----------|---------|----------|
|  | 210172 | 120 in. | 165 lbs. | 4.5 in. | 3.75 in. |
| | 210495 | 60 in. | 82.5 lbs. | | |
| | 210563 | 24 in. | 33 lbs. | | |
| | 210602 | 12 in. | 16.5 lbs. | | |

4.5 RHSL

| Components | Part | MN | Notes |
|---|---|--------|--------|
|  | 4.5 in. Sonic Sampler Barrel RHSL | 227183 | 60 in. |
| | | 223849 | 12 in. |
| | | 229565 | 6 in. |
| | SUB 4.5 in. HD RHSL Box to 4.5 RHSL Pin | 227102 | |



Bits

| Components | Part | MN | Notes |
|---|------------------------------------|--------|----------------------------|
|  | 4.5 in. Sonic Bit RHSL SDT45, Dome | 231316 | 4.93 in. OD 2.65 in. ID |
|  | 4.5 in. Sonic Bit RHSL SDT45, Para | 223864 | 4.93 in. OD 2.65 in. ID |
|  | 4.5 in. Sonic Bit LHSL SDT45, Dome | 226395 | 4.93 in. OD 2.65 in. ID |
|  | 4.5 in. Sonic Bit LHSL SDT45, Para | 210566 | 4.93 in. OD 2.65 in. ID |

OUTER**6.0 in. Sonic Casing RHSL**

| Components | MN | Length | Weight | OD | ID |
|---|--------|---------|------------|---------|----------|
|  | 210979 | 120 in. | 225 lbs. | 6.0 in. | 5.25 in. |
| | 210648 | 60 in. | 112.5 lbs. | | |
| | 211174 | 24 in. | 45 lbs. | | |
| | 211277 | 18 in. | 33.75 lbs. | | |
| | 212350 | 12 in. | 22.5 lbs. | | |
| | 212351 | 6 in. | 11.25 lbs. | | |

Bits

| Components | Part | MN | Notes |
|---|------------------------------|--------|----------------------------|
|  | 6.0 in. Sonic Bit RHSL, Dome | 210749 | 6.38 in. OD 5.02 in. ID |
| | 6.0 in. Sonic Bit RHSL, Para | 213325 | 6.45 in. OD 5.02 in. ID |
|  | 6.0 in. Sonic Bit RHSL CC | 226017 | 6.00 in. OD 5.25 in. ID |

COMBINED COMPONENTS**Spindle Adapters**

| Components | Part | MN | Notes |
|--|---|--------|-------|
|  | GV5 ADPT 6.0 RHSL x 4.5 LHSL x 3.5 LHSL | 218880 | |
| | GV5 ADPT 6.0 RHSL x 4.5 HD x 3.5 LHSL | 228765 | HD |
| | GV4 ADPT 6.0 RHSL x 4.5 LHSL x 3.5 LHSL | 211278 | |
| | GV4 ADPT 6.0 RHSL x 4.5 HD x 3.5 LHSL | 234730 | HD |

Accessories

| Components | Part | MN | Notes |
|---|--|--------|----------------------|
|  | 1.25 in. Nylon Ball | 101120 | |
|  | 6.0 in. Swivel Lift Cap RHSL | 210649 | Pin |
|  | 4.5 in. HD Swivel Lift Cap RHSL | 228940 | Pin |
|  | 4.5 in. Swivel Lift Cap LHSL | 210606 | Pin |
|  | 2.25 in. Spring Assisted Swivel Lift Cap | 217609 | Pin |
|  | Rod Wiper Donut | 600624 | 6.0 in. |
|  | Rod Wiper Donut | 600448 | 4.5 in. |
|  | DT45/MC7 Liner Cutter | 206987 | |
|  | Liner Cutter Replacement Blades | 600985 | Quantity: 5 |
|  | Core Bags (SDT45, WWL45, 4X6) | 106477 | 8 in. flat x 725 ft. |
|  | Thread Compound | 600729 | 1 Gallon |

Subs / Adapters

| Components | Part | MN | Notes |
|---|-----------------------------|--------|---------------------------|
|  | 4.5 HD Pin x 6.0 RHSL Box | 226741 | 8.50 in. S-S |
| | 4.5 HD Box x 4.5 HD Pin | 229271 | 4.00 in. S-S Sub Saver |
| | 4.5 LHSL Box x 4.5 LHSL Pin | 212679 | 4.00 in. S-S Sub Saver |

S-S (Shoulder to Shoulder)

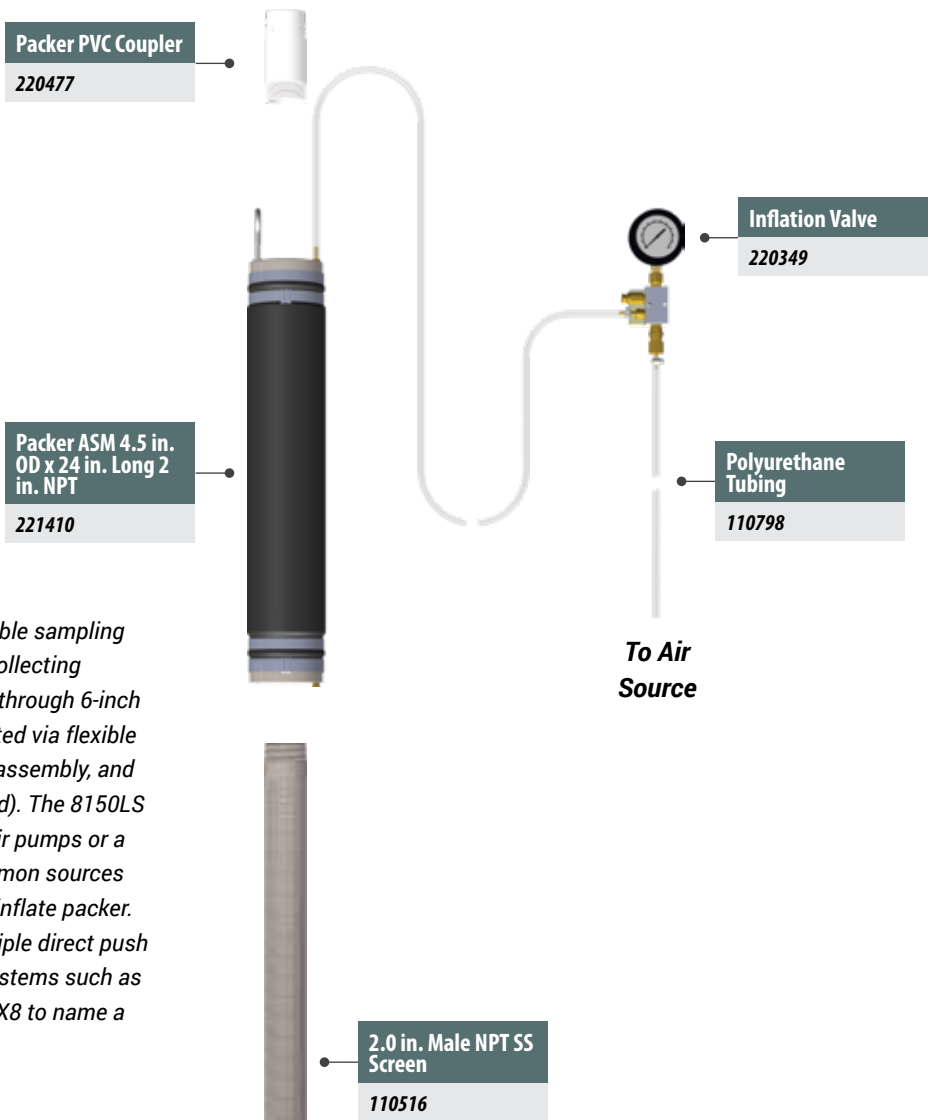

Packer-based, deployable sampling system designed for collecting groundwater samples through 6-inch casing. Packer is inflated via flexible tubing, inflation valve assembly, and air supply (not included). The 8150LS on-board air, manual air pumps or a small air tank are common sources for compressed air to inflate packer. Can be used with multiple direct push and sonic sampling systems such as SDT60, 4X6, DT60 or 6X8 to name a few.

Key Features

- deployed inside 6-inch casing with standard 2-inch schedule 40 PVC
- helps ensure groundwater being sampled is representative of that particular interval
- prevents the screen section from being exposed to the water inside the casing
- modular design allows multiple packers to be used for different isolation options

Sampling Components

| Components | Part | MN | Notes |
|------------|---|--------|-----------------------------------|
| | PVC Riser | 104378 | 2 in. x 60 in. |
| | Packer PVC Coupler | 220477 | |
| | Inflation Valve | 220349 | |
| | Polyurethane Tubing | 110798 | 3/8 in. OD x 1/4 in. ID x 100 ft. |
| | Packer ASM 4.5 in. OD x 24 in. Long 2 in. NPT | 221410 | |
| | 2.0 in. Male NPT SS Screen | 110516 | 5 ft. |

- 50K Dynamic Force
- Designed for the Geoprobe® 8150LS & 8250LS Rotary Sonic Rigs



Geoprobe® GV5 Sonic Head

Automatic Drop Hammer

(Optional)

High-Speed Coring Head

(Optional)